

Component List

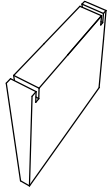

A - Leg x 2
(Left and Right)

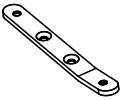

B - Bracket x 4

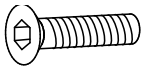

C - Mounting Screw x 16



D - Stretchers x 2



E - Levelers x 4



F - Rubber Bumper
Inserts x 4

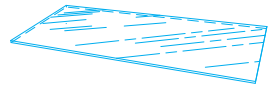

G - Glass top x 1



Medium Hex Wrench x 1

Your Marina Furniture is engineered for easy assembly. Carefully follow this procedure to prevent any damage.

NOTE: This instruction sheet is intended for the 2201 and 2223 of the Marina Table collection; model 2201 is shown for illustration.

Placement and Maintenance

Marina Furniture is designed for indoor use on level floors. Clean glass with glass cleaner, and steel parts and wood veneer with a moist cloth.

Step 1

Unpack and identify the parts listed. The assembly workspace should be a non-marring surface such as carpet. For missing hardware pieces please contact BDI Customer Service at customerservice@bdiusa.com. For all other concerns, please contact your BDI Retailer.

Step 2

Attach brackets to legs.

Using the Medium Hex Wrench, fasten the **Brackets (B)** to **Leg (A)** with the **Mounting Screw (C)**. Assure correct orientation of bracket.

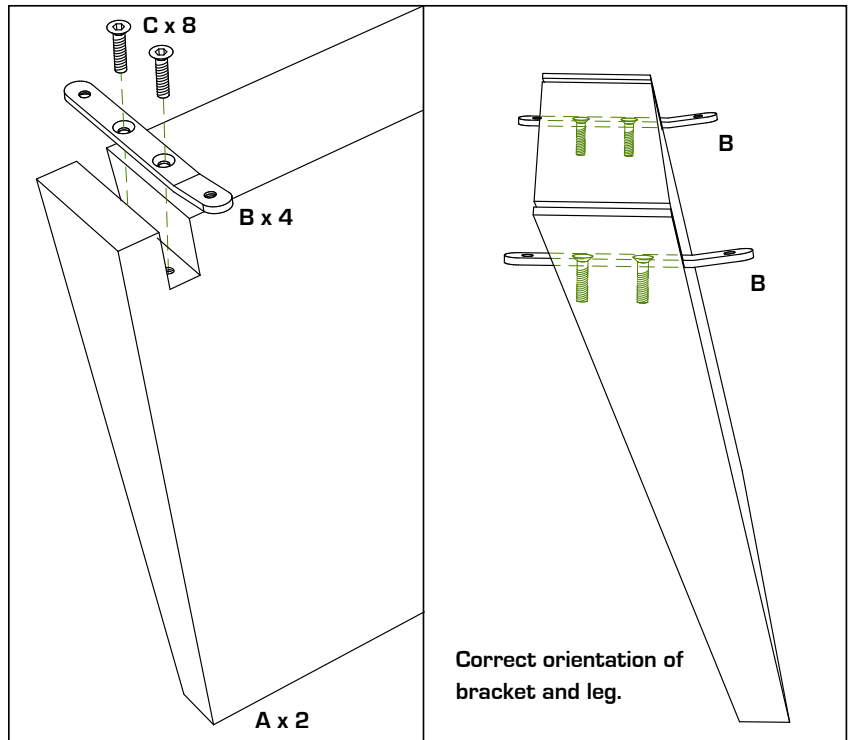

Step 3

Attach Legs to Stretchers.

Using the **Medium Hex Wrench**, fasten the **Legs (A)** to the **Stretchers (D)** with the **Mounting Screw (C)**. Install **Levelers (E)** to the bottom of the **Legs (A)**.

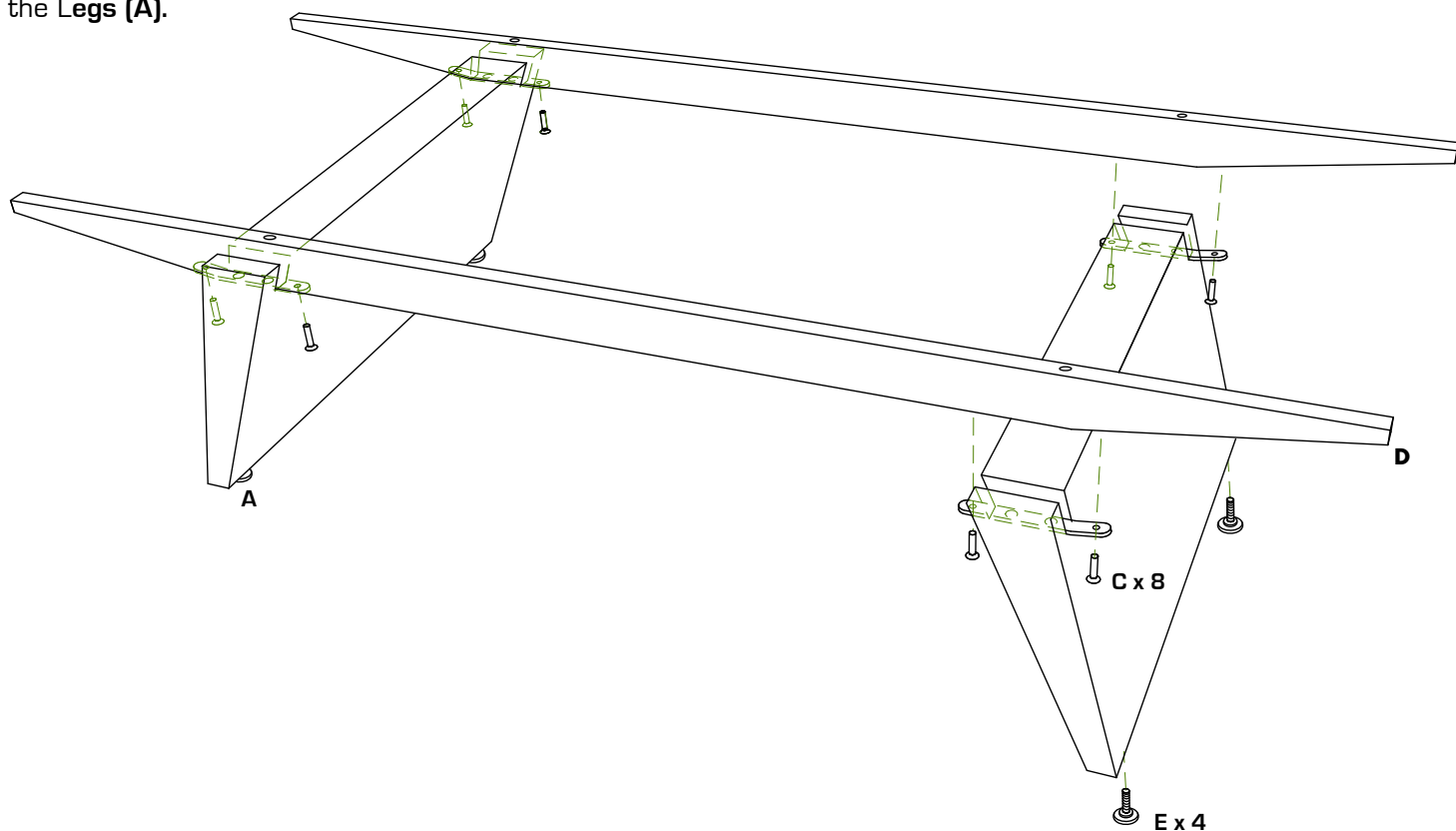

Step 4

Install Rubber Bumper Inserts and Glass Top.

Install **Rubber Bumpers (E)** to the four holes located in the **Stretchers (D)** and then position **Glass Top (F)**.

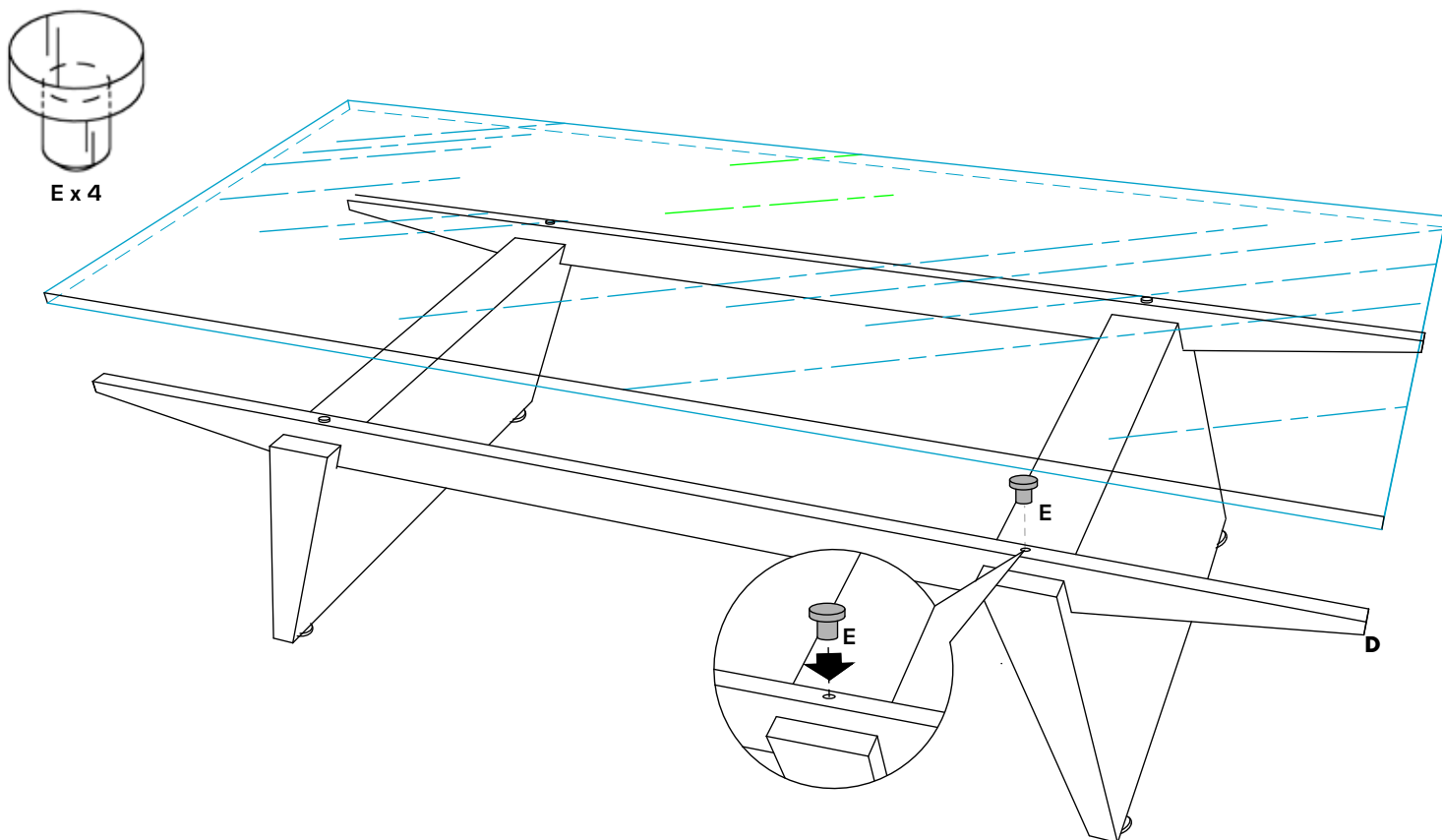

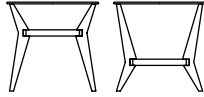

Component List

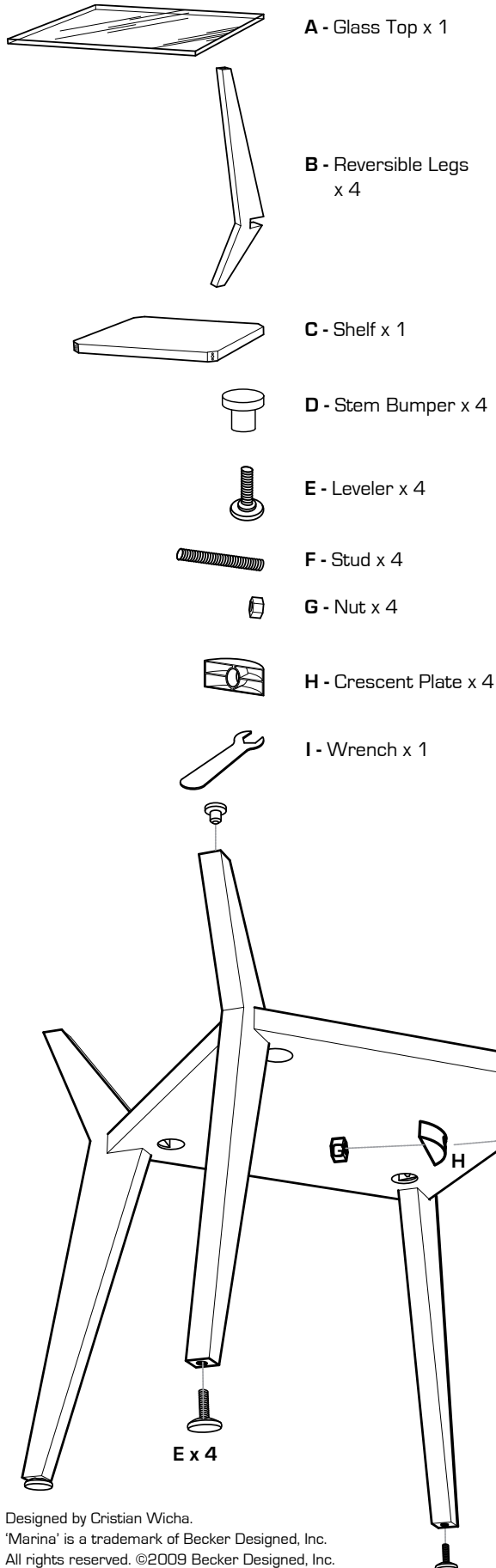

Your Marina Furniture is engineered for easy assembly. Carefully follow this procedure to prevent any damage.

Placement and Maintenance

Marina Furniture is designed for indoor use on level floors. Clean glass with glass cleaner, and steel parts and wood veneer with a moist cloth.

Step 1

Unpack and identify the parts listed. The assembly workspace should be a non-marring surface such as carpet. For missing hardware pieces please contact BDI Customer Service at customerservice@bdiusa.com. For all other concerns, please contact your BDI Retailer.

Step 2

The Marina End Table can be assembled with either a HIGHER or LOWER shelf location. Determine which orientation you prefer before completing remaining steps.



Step 3

Thread one (1) **Stud (F)** into each **Leg (B)** at notch in leg and finger-tighten.

Step 4

Fasten each properly-oriented Leg to the Shelf by inserting the Stud with gentle force into each Shelf corner; then install one (1) **Crescent Plate (H)** on inserted end of **Stud (F)** with one (1) **Nut (G)**.

NOTE: Round surface of Crescent Plate must mate flush with curved cut-out area within shelf.

Tighten each **Nut (G)** with supplied **Wrench (I)**.

Step 5

Invert **Leg (B) & Shelf (C)** assembly so that the bottom of each **Leg (B)** is facing UP; then thread one (1) **Leveler (E)** into the bottom of each Leg.

Step 6

Invert assembly again and insert one (1) **Stem Bumper (D)** into the top of each Leg.

Step 7

Carefully center and rest **Glass Top (A)** on **Stem Bumper (D)** to complete assembly.